



# iPanrex®

PNEUMATIC FASTENING TOOLS

### Panrex OEM Process



### Project Management



# iPanrex®

PNEUMATIC FASTENING TOOLS

**PANREX INDUSTRIAL CO., LTD.**

No.45, Tucheng Rd., Dali Dist., Taichung City, Taiwan, 41274.

TEL: 886-4-2493-1538 FAX:886-4-2493-1539 <http://www.panrex.com.tw>

E-mail:

[panrex-wiichen@panrex.com.tw](mailto:panrex-wiichen@panrex.com.tw)

[panrex@hibox.hinet.net](mailto:panrex@hibox.hinet.net)



2026.01

**Pay Attention to Nothing  
but Real EXellence.**

[www.panrex.com.tw](http://www.panrex.com.tw)



# **iPanrex**

**Precision, Achievement,  
Novelty, Reliability,  
Excellence, eXpertise**



Panrex is dedicated to advancing technology through extensive research and development. Establishing a complete fastening system to ensure our tools are safe, convenient, and easy to operate is also our goal.

Certified by international standards, Panrex has also developed specialized techniques as follows:

# Index

**p03-08**  
INDUSTRIAL PALLET COIL NAILER

**p09-12**  
CONSTRUCTION FASTENING SYSTEM

**p13-16**  
FRAMING FASTENING SYSTEM

**p17-22**  
INDUSTRIAL STAPLERS

**p23-26**  
BRADDERS/PIN NAILERS

**p27-28**  
FLOORING FASTENING SYSTEM

**p29-30**  
CONCRETE FASTENING SYSTEM

**p31-32**  
DRYWALL/SCREW FASTENING SYSTEM

**p33-34**  
C-RING TOOL/HOG-RING GUN

**p35**  
SPECIAL FASTENING SYSTEM

**p36**  
ACCESSORIES



ONE YEAR WARRANTY WILL APPLY TO PANREX' TOOL,  
EXCEPT NORMAL WEARING PARTS.



**1**  
**NAIL-DRIVING WITH SAFETY DEVICE:**

Slim nose easy to aim  
(U.S.PATENT 6450387)



**2**  
**POWERFUL & EASY CAP RELEASE:**

(U.S.PATENT 6651863)



**3**  
**ADJUSTABLE WORK CONTACTING ELEMENT**

Depth of drive adjustment by wheel. (U.S.PATENT 6866177)



**4**  
**ONE STEP JAM CLEARANCE:**

(PATENT pending)



**5**  
**ANTI-DOUBLE FIRE MECHANISM, SINGLE OR CONTACT FIRING:**

No adjustment needed to switch from one to the other.

(U.S. PATENT 6419140, 6357647)  
(G.M.PATENT Nr20217706.8)

**6** **DRY-FIRE LOCK:** (U.S. PATENT 7004368)

**7** **PATENTED DRIVER DESIGN FOR DURABLE USE**

**8** **UNIQUE NAIL GUIDE LOCK AND EASY NAIL LENGTH ADJUSTMENT** (PATENT 220112)

**9** **FAST-CYCLE RATE TO 15 NAILS/SECOND**(110Psi)

# INDUSTRIAL PALLET COIL NAILER

Downward exhaust optional



For bigger head size nails

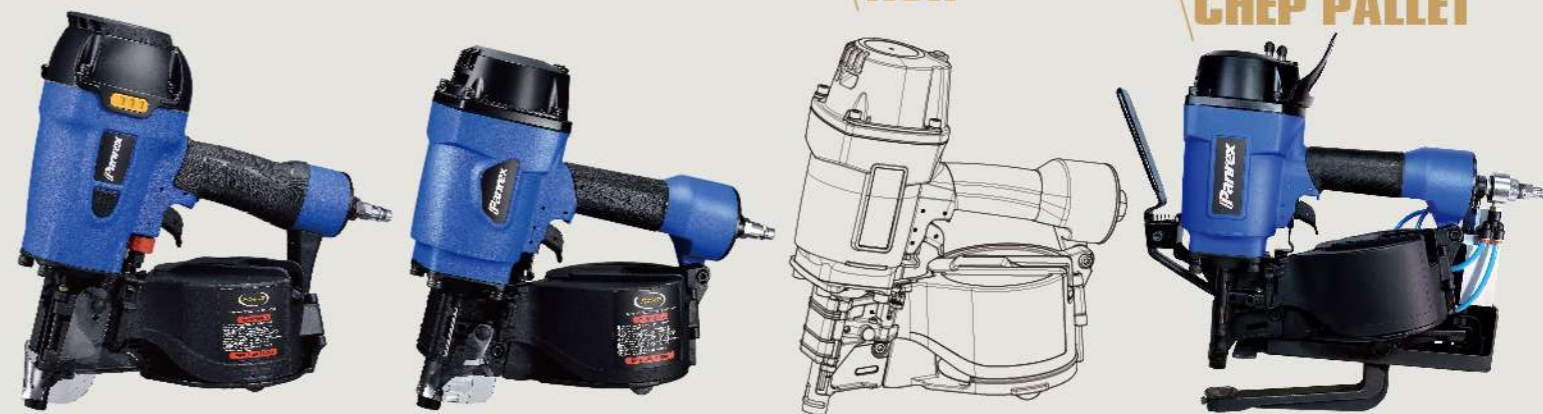

	PCN-55M.1 PRO	PCN-65.1 PRO	PCN-65H.1 PRO	PCN-670SA.1	PCN-70	PCN-83	PCN-70CL
NAIL SPEC	LENGTH	1"-2 1/4" (25-57mm)	1 1/4"-2 1/2" (32-65mm)	1 1/4"-2 1/2" (32-65mm)	1 1/2"-2 3/4" (38-70mm)	1 3/4"-2 3/4" (45-70mm)	1 3/4" (45mm)
	SHANK	.083"-.099" (2.10-2.50mm)	.083"-.099" (2.10-2.50mm)	.092"-.113" (2.30-2.87mm)	.092"-.131" (2.30-3.30mm)	.092"-.118" (2.30-3.00mm)	.114" (2.9mm)
	HEAD DIA.	.189"-.236" (4.8-6.0mm)	MAX .244" (6.2mm)	<b>MAX .283" (7.2mm)</b>	.220"-.275" (5.6-7.0mm)	.220"-.275" (5.6-7.0mm)	.275" (7.0mm)
	PITCH	6.8-8.0mm	6.8-8.0mm	6.0-8.0mm	8.0mm	8.0mm	8.0mm
TOOL INFO	WEIGHT	5.48 lbs (2.49kgs)	5.74 lbs (2.61kgs)	5.74 lbs (2.61kgs)	6.80 lbs (3.09kgs)	7.30 lbs (3.32kgs)	15.86 lbs (7.21kgs)
	LOADING CAPACITY	300-350 nails	300-350 nails	225-300 nails	225-300 nails	225-300 nails	225-300 nails
	OPERATION PRESSURE	70-120psi	70-120psi	70-120psi	70-120psi	70-120psi	70-120psi
	ACCESSORIES	Secondary Safety			Secondary Safety		

# INDUSTRIAL PALLET COIL NAILER

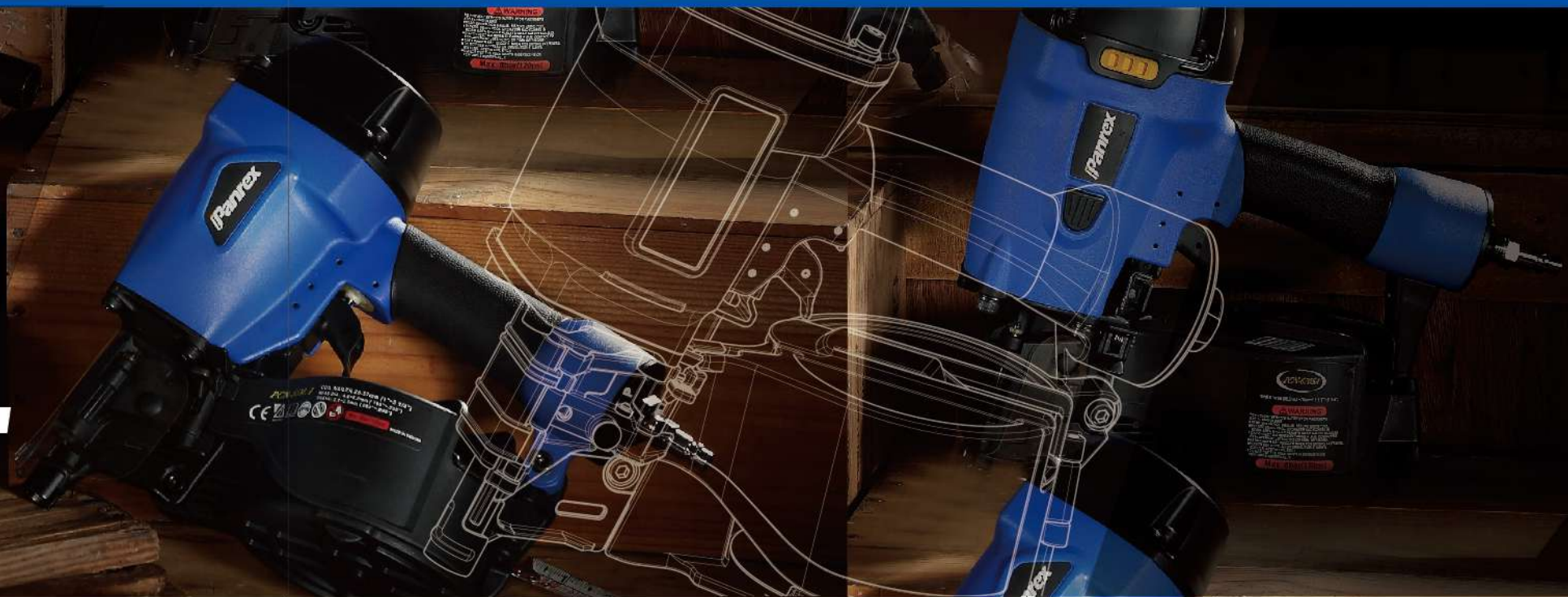

		<b>PCN-945EP</b>	<b>PR-9100EP.1</b>	<b>PCN-790PRO</b>	<b>PR-790P</b>	<b>PR-8100C</b>	<b>PR-9130P</b>
<b>NAIL SPEC</b>	LENGTH	3/4"-1 3/4" (19-45mm)	2 3/4"-3 1/2" (70-90mm)	2"-3 1/2" (50-90mm)	2"-3 1/2" (50-90mm)	2 1/2"-4" (65-100mm)	2 1/2"-5 1/8" (65-130mm)
	SHANK	.165" (4.20mm)	.150" (3.80mm)	.099"-.150" (2.50-3.80mm)	.099"-.150" (2.50-3.80mm)	.099"-.150" (2.50-3.80mm)	.099"-.150" (2.50-3.80mm)
	HEAD DIA.	.406" (10.3mm)	.338" (8.6mm)	MAX .283" (7.2mm)	.236"-.295" (6.0-7.5mm)	.256"-.295" (6.5-7.5mm)	.256"-.338" (6.5-8.6mm)
	PITCH	10.7mm	10.5±0.3mm	8.0mm	8.0mm	8.0±0.3mm	10.5±0.3mm
<b>TOOL INFO</b>	WEIGHT	5.32 lbs (2.42kgs)	12.32 lbs (5.60kgs)	7.94 lbs (3.61kgs)	7.99 lbs (3.63kgs)	12.45 lbs (5.66kgs)	13.29 lbs (6.04kgs)
	LOADING CAPACITY	120 nails	150-300 nails	150-300 nails	150-300 nails	150-300 nails	120-300 nails
	OPERATION PRESSURE	70-120psi	80-120psi	70-120psi	70-120psi	80-120psi	80-120psi
	ACCESSORIES					Secondary Safety	



# INDUSTRIAL PALLET COIL NAILER **Auto Machine**



Two-piece nose



Remote Valve



	PCN-55M.1 PAL PRO	PCN-65H.1 PAL PRO	PCN-70PAL	PCN-70A2	PCN-83PAL	PCN-790PAL	
NAIL SPEC	LENGTH	1"-2 1/4" (25-57mm)	1 1/4"-2 1/2" (32-65mm)	1 3/4"-2 3/4" (45-70mm)	1 3/4"-2 3/4" (45-70mm)	2"-3 1/4" (50-83mm)	2"-3 1/2" (50-90mm)
	SHANK	.083"-.099" (2.10-2.50mm)	.092"-.113" (2.30-2.87mm)	.092"-.118" (2.30-3.00mm)	.092"-.118" (2.30-3.00mm)	.099"-.131" (2.50-3.30mm)	.099"-.150" (2.50-3.80mm)
	HEAD DIA.	.189"-.236" (4.8-6.0mm)	MAX .283" (7.2mm)	.220"-.275" (5.6-7.0mm)	.220"-.275" (5.6-7.0mm)	.232"-.287" (5.9-7.3mm)	MAX .283" (7.2mm)
	PITCH	6.8-8.0mm	6.0-8.0mm	8.0mm	8.0mm	8.0mm	8.0mm
TOOL INFO	WEIGHT	4.73 lbs (2.15kgs)	4.73 lbs (2.15kgs)	6.01 lbs (2.73kgs)	7.37 lbs (3.35kgs)		6.82 lbs (3.10kgs)
	LOADING CAPACITY				225-300 nails		
	OPERATION PRESSURE	70-120psi	70-120psi	70-120psi	70-120psi	70-120psi	70-120psi
	ACCESSORIES	remote valve	remote valve	remote valve		remote valve	remote valve



0 degree



For conical coil nails

For bigger head size nails



		PCN-32	PCN-452S	PCN-557S	PCN-557C	PCN-565H	PCN-565S	PCN-675S
NAIL SPEC	LENGTH	9/16"-1 1/4" (15-32mm)	1"-2" (25-50mm)	1"-2 1/4" (25-57mm)	1"-2 1/4" (25-57mm)	1"-2 1/2" (25-65mm)	1"-2 1/2" (25-65mm)	1 1/2"-3" (38-75mm)
	SHANK	.079"-.086" (2.00-2.20mm)	.063"-.099" (1.59-2.50mm)	.083"-.092" (2.10-2.30mm)	.083"-.092" (2.10-2.30mm)	.092"-.113" (2.30-2.87mm)	.092"-.113" (2.30-2.87mm)	.092"-.131" (2.30-3.30mm)
	HEAD DIA.	.169"-.189" (4.3-4.8mm)	.181"-.197" (4.6-5.0mm)	.189"-.236" (4.8-6.0mm)	.189"-.236" (4.8-6.0mm)	<b>MAX .275" (7.0mm)</b>	.197"-.236" (5.0-6.0mm)	MAX .283" (7.2mm)
	PITCH	5.0±0.4mm	6.0-6.8mm	6.0-6.8mm	6.0-6.8mm	8.0mm	8.0mm	7.6-8.0mm
TOOL INFO	WEIGHT	2.79 lbs (1.27kgs)	4.00 lbs (1.82kgs)	5.21 lbs (2.37kgs)	5.19 lbs (2.36kgs)	5.54 lbs (2.52kgs)	5.52 lbs (2.51kgs)	6.69 lbs (3.04kgs)
	LOADING CAPACITY	150-300 nails	400 nails	250-400 nails	250-400 nails	250-400 nails	250-400 nails	225-300 nails
	OPERATION PRESSURE	70-120psi	70-120psi	70-120psi	70-120psi	70-120psi	70-120psi	70-120psi
	ACCESSORIES							

# CONSTRUCTION FASTENING SYSTEM

**ADJUSTABLE AIR DEFLECTOR**

**BUILT-IN SOUND REDUCER**  
Low noise and vibration

**ERGONOMIC DESIGN**  
Center of gravity is closer to the trigger, providing better balance, also offers the lowest recoil for a tool of its size.

**POWERFUL**  
Driving power: 600 inch-lbs

**FAST-CYCLE RATE TO 15 NAILS/SECOND (110Psi)**

**ANTI-DOUBLE FIRE MECHANISM, SINGLE OR CONTACT FIRING:**  
No adjustment needed to switch from one to the other. (U.S. PATENT 6419140)

**DURABLE AND RELIABLE:**  
Rugged design will stand up to the demands of the job in any kind of weather.

Heavy duty

For Roofing



		PCN-790S	PCN-790HS	PCN-890H	PCN-945P	PCN-950PRO
NAIL SPEC	LENGTH	2"-3 1/2" (50-90mm)	2"-3 1/2" (50-90mm)	2"-3 1/2" (50-90mm)	3/4"-1 3/4" (19-45mm)	3/4"-2" (19-50mm)
	SHANK	.099"-.150" (2.50-3.80mm)	.099"-.150" (2.50-3.80mm)	.118"-.161" (3.00-4.10mm)	.120" (3.05mm)	.120" (3.05mm)
	HEAD DIA.	.256"-.295" (6.5-7.5mm)	.256"-.295" (6.5-7.5mm)	MAX .338" (8.6mm)	.394" (10.0mm)	.394" (10.0mm)
	PITCH	8.0mm	8.0mm	7.5-10.0mm	8.5mm	8.5mm
TOOL INFO	WEIGHT	8.05 lbs (3.66kgs)	7.88 lbs (3.58kgs)	8.07 lbs (3.67kgs)	5.37 lbs (2.44kgs)	5.37 lbs (2.44kgs)
	LOADING CAPACITY	150-300 nails	150-300 nails	150-250 nails	120 nails	120 nails
	OPERATION PRESSURE	70-120psi	70-120psi	70-120psi	70-120psi	70-120psi
	ACCESSORIES					

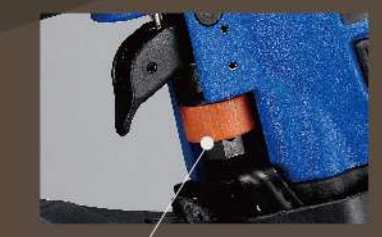

**ADJUSTABLE WORK CONTACTING ELEMENT**  
Depth of drive adjustment by wheel. (U.S. PATENT 6866177)



**EASY DIAL NAIL SIZE ADJUSTMENT**  
(R.O.C. PATENT 220112)



**EXCLUSIVE NOZZLE TIP TO FIT SIDING DECKING OPERATION**

## CONSTRUCTION FASTENING System APPLICATION

SIDING / FENCING / EXTERIOR TRIM / SHEATHING  
SUBFLOORS / ROOF DECKING / EXTERIOR DECK  
FURRING / STRAPPING

# FRAMING FASTENING SYSTEM

**SAFETY LOCK-OUT MECHANISM**  
Tool will not fire unless more than three nails are in the magazine

**LIGHTEST WEIGHT DESIGN**

**ADJUSTABLE WORK CONTACTING ELEMENT**  
Depth of drive adjustment element on the tool.

**POWERFUL AND EASY CAP RELEASE**  
(U.S.PATENT 6651863)

**DURABLE AND RELIABLE:**  
Rugged design will stand up to the demands of the job in any kind of weather.

**ERGONOMIC DESIGN**  
Center of gravity is closer to the trigger, providing better balance, also offers the lowest recoil for a tool of its size

**ANTI-DOUBLE FIRE MECHANISM, SINGLE OR CONTACT FIRING:**  
No adjustment needed to switch from one to the other. (U.S. PATENT 6419140)

**PUSHER & FOLLWER PROTECTOR DESIGN**



		<b>PR-2202 I</b>	<b>PR-1602 I.1</b>	<b>PR-1302 I.1</b>	<b>PR-902 I P.1</b>	<b>PR-002 I P.1</b>
<b>NAIL SPEC</b>	<b>LENGTH</b>	5 3/4"-8 5/8" (145-220mm)	4"-6 1/4" (100-160mm)	3 1/2"-5 1/8" (90-130mm)	2"-3 1/2" (50-90mm)	2 3/8"-4" (60-100mm)
	<b>SHANK</b>	.150"-.197" (3.80-5.00mm)	.150"-.197" (3.80-5.00mm)	.113"-.161" (2.87-4.10mm)	.113"-.161" (2.87-4.10mm)	.113"-.161" (2.87-4.10mm)
	<b>HEAD DIA.</b>	.362"-.386" (9.2-9.8mm)	.354" (9.0mm)	.323" (8.2mm)	.268"-.338" (6.8-8.6mm)	.268"-.338" (6.8-8.6mm)
	<b>COLLATION ANGLE</b>	19°-21°	21°	21°	21°	21°
<b>TOOL INFO</b>	<b>WEIGHT</b>	20.53 lbs (9.33kgs)	15.66 lbs (7.12kgs)	14.17 lbs (6.44kgs)	7.83 lbs (3.56kgs)	7.88 lbs (3.58kgs)
	<b>LOADING CAPACITY</b>	54 nails	50 nails	64 nails	54 nails	61 nails
	<b>LOADING DIRECTION</b>	Top	Top	Top	Top	Top
	<b>OPERATION PRESSURE</b>	95-145psi	80-120psi	80-120psi	80-120psi	80-120psi
	<b>ACCESORRIES</b>					

**21 degree**

## FRAMING FASTENING System

**TOP Loading**

### APPLICATION

FRAMING / WALL SHEATHING /  
ROOF SHEATHING / FLOOR DECKING /  
BLOCKING SUBASSEMBLIES



# FRAMING FASTENING SYSTEM

**NEW**  
Compact Design



**NEW**  
Compact Design



	<b>PF-9021</b>	<b>PF-0021</b>	<b>PR-8321</b>	<b>PR-9017P.1</b>	<b>PR-9034</b>	<b>PF-0034</b>	
<b>NAIL SPEC</b>	LENGTH	2"-3 1/2" (50-90mm)	2"-4" (50-100mm)	2"-5 3/4" (50-83mm)	2"-3 1/2" (50-90mm)	2"-5 3/4" (50-90mm)	
	SHANK	.113"-.131" (2.87-3.30mm)	.113"-.161" (2.87-4.10mm)	.113"-.161" (2.87-4.10mm)	.113"-.133" (2.87-3.40mm)	.113"-.150" (2.87-3.80mm)	.113"-.150" (2.87-3.80mm)
	HEAD DIA.	.268"-.315" (6.8-8.0mm)	.299"-.346" (7.6-8.8mm)	.268"-.338" (6.8-8.6mm)	.307" (7.8mm)	.299" (7.6mm)	.299" (7.6mm)
	COLLATION ANGLE	21°	21°	21°	17°	34°	34°
<b>TOOL INFO</b>	WEIGHT	8.03 lbs (3.65kgs)	8.14 lbs (3.70kgs)	8.45 lbs (3.84kgs)	7.88 lbs (3.58kgs)	7.52 lbs (3.42kgs)	7.81 lbs (3.55kgs)
	LOADING CAPACITY	59 nails	58 nails	54 nails	55 nails	87-89 nails	74 nails
	LOADING DIRECTION	Rear	Rear	Top	Top	Rear	Rear
	OPERATION PRESSURE	80-120psi	80-120psi	80-120psi	80-120psi	80-120psi	80-120psi
	ACCESSORIES						

**21 degree**

**17 degree**

**34 degree**



# INDUSTRIAL STAPLERS

R for roofing

NEW

NEW

2 in 1 design



**PS-2540S2.1**  
**PS-2540S2.1R**

**PS-2550S2**

**PS-2640P**

**PS-2650P**

**PR-15864Q**

**PS-1695IC-1**  
**PR-1695IP**

NAIL SPEC	LENGTH	1/2"-1 5/8" (13-40mm)	1"-2" (25-50mm)	1/2"-1 5/8" (13-40mm)	1"-2" (25-50mm)	Q type nails 1 1/4"-2 1/2" (32-65mm)		1"-2" (25-50mm)
	CROWN SIZE	1" (25.40mm)	1" (25.40mm)	1" (26.40mm)	1" (26.40mm)	13/32"-7/16" (10.60-11.20mm)		15/32"-1/2" (12.20-12.70mm)
W X T	.055"x.063" (1.40x1.60mm)	.055"x.063" (1.40x1.60mm)	.055"x.063" (1.40x1.60mm)	.055"x.063" (1.40x1.60mm)	.075"x.067" (1.90x1.70mm)	.063"x.055" (1.60x1.40mm)	.063" x .055" (1.60 x 1.40mm)	
GAUGE	16GA	16GA	16GA	16GA	15GA	16GA	16GA	
TOOL INFO	WEIGHT	4.84 lbs (2.20kgs)	5.08 lbs (2.31kgs)	4.84 lbs (2.20kgs)	5.08 lbs (2.31kgs)	5.92 lbs (2.69kgs)		4.73 lbs (2.15kgs)
	LOADING CAPACITY	147 staples	147 staples	147 staples	147 staples	127 staples	147 staples	147 staples
	OPERATION PRESSURE	70-120psi	70-120psi	70-120psi	70-120psi	80-120psi	80-120psi	80-120psi
	ACCESSORIES							Remote Fire Valve

**Wide Crown Stapler**

**Medium Crown Stapler**

# INDUSTRIAL STAPLERS

## APPLICATION

SHEATHING / SUBFLOORING / ROOF DECKING FURNITURE FRAMES / PALLETS / VINYL SIDING CRATE AND BOX ASSEMBLY

# INDUSTRIAL STAPLERS

POWERFUL AND PATENTED DRIVER DESIGN FOR DURABLE USE

LOW NOISE AND LOW VIBRATION

ANTI-DOUBLE FIRE MECHANISM, SINGLE OR CONTACT FIRING:  
No adjustment needed to switch from one to the other. (U.S. PATENT 6419140)

FAST-CYCLE RATE TO 15 NAILS/SECOND (110Psi)

ERGONOMIC DESIGN  
Center of gravity is closer to the trigger, providing better balance, also offers the lowest recoil for a tool of its size

LIGHTEST WEIGHT DESIGN  
ONLY 4.8lbs(2.18kg)

ADJUSTABLE WORK CONTACTING ELEMENT  
Depth of drive adjustment element on the tool.

ONE STEP JAM CLEARANCE  
(PATENT PENDING)

DURABLE AND RELIABLE  
Rugged design will stand up to the demands of the job in any kind of weather.

FOR FLOORING TIP

EASY LOADING AND PUSHER PROTECTOR DESIGN (PATENT PENDING)

SLIM SAFETY LEVER FOR SELECT



	PS-16851C PR-16851P	PR-16840B	PR-16851B	PR-1440B	
NAIL SPEC	LENGTH	3/4"-2" (19-50mm)	9/16"-1 5/8" (15-40mm)	3/4"-2" (19-50mm)	
	CROWN SIZE	13/32"-7/16" (10.60-11.20mm)	13/32"-7/16" (10.60-11.20mm)	13/32"-7/16" (10.60-11.20mm)	
	W X T	.063"x.055" (1.60x1.40mm)	.062" x .057" (1.57 x 1.44mm) .057" x .051" (1.45 x 1.30mm)	.063" x .055" (1.60 x 1.40mm)	.063" x .055" (1.60 x 1.40mm) .057" x .051" (1.45 x 1.30mm)
	GAUGE	16GA	16GA/17GA	16GA	16GA/17GA
TOOL INFO	WEIGHT	4.91 lbs (2.23kgs)	4.36 lbs (1.98kgs)	4.75 lbs (2.16kgs)	4.91 lbs (2.23kgs)
	LOADING CAPACITY	147 staples	150 staples	147 staples	130 staples
	OPERATION PRESSURE	80-120psi	80-120psi	80-120psi	80-120psi
	ACCESSORIES	Remote Fire Valve			Long magazine (165 staples)

**Medium Crown Stapler**



# INDUSTRIAL STAPLERS

Heavy duty



Light weight



Heavy duty



Light weight



	PR-9040S.1	PR-9040P	PR-9240B	PR-9240P	8016A	7116A	
NAIL SPEC	LENGTH	1/2"-1 5/8" (12-40mm)	1/2"-1 5/8" (12-40mm)	1/2"-1 5/8" (12-40mm)	3/16"-5/8" (5-16mm)	3/16"-5/8" (5-16mm)	
	CROWN SIZE	7/32" (5.80mm)	7/32" (5.80mm)	5/16"-11/32" (8.60-8.85mm)	1/2" (12.90mm)	11/32" (9.10mm)	
	W X T	.050"x.039" (1.25x1.00mm)	.050"x.039" (1.25x1.00mm)	.050"x.041" (1.27x1.05mm)	.050" x .039" (1.25 x 1.00mm)	.037" x .026" (0.95 x 0.65mm)	.030" x .024" (0.75 x 0.60mm)
	GAUGE	18GA	18GA	18GA	18GA	21GA	22GA
TOOL INFO	WEIGHT	3.50 lbs (1.59kgs)	2.66 lbs (1.21kgs)	3.32 lbs (1.51kgs)	2.62 lbs (1.19kgs)	1.98 lbs (0.90kgs)	1.98 lbs (0.90kgs)
	LOADING CAPACITY	158 staples	215 staples	175 staples	190 staples	100 staples	150 staples
	OPERATION PRESSURE	70-120psi	70-120psi	70-120psi	70-120psi	70-100psi	70-100psi
	ACCESSORIES	Long magazine (215 staples)		Long magazine (210 staples)		Long magazine (270 staples)	Long magazine (400 staples)

**Narrow Crown Staple**

**Fine Wire**

# BRADDERS/ PIN NAILERS

ADJUSTABLE AIR DEFLECTOR

BUILT-IN SOUND REDUCER  
Low noise and vibration

PATENTED DRIVER DESIGN FOR DURABLE USE

NO-MAR RUBBER TIP FOR PERFECT FINISH

ANTI-DOUBLE FIRE MECHANISM, SINGLE OR CONTACT FIRING:  
No adjustment needed to switch from one to the other.(U.S. PATENT 6419140)

DUAL POSITION BELT HOOK

QUICK AND EASY SIDE LOADING

DEPTH-OF-DRIVE ADJUSTMENT  
(U.S. PATENT 6866177)

Updated version

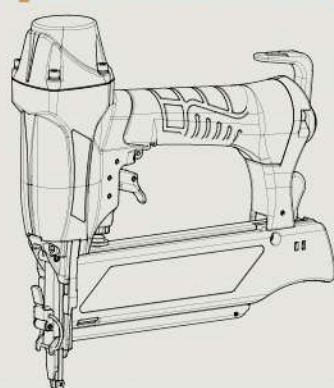

	PR-1850 PRO	PR-1850F	PR-1664 PRO.1	PR-1650	PR-1845	
NAIL SPEC	LENGTH	9/16"-2" (15-50mm)	9/16"-2" (15-50mm)	3/4"-2 1/2" (19-65mm)	9/16"-2" (15-50mm)	9/16"-1 3/4" (15-45mm)
	HEAD DIA.	.075" (1.90mm)	.075" (1.90mm)	.118" (3.00mm)	.118" (3.00mm)	.075" (1.90mm)
	W X T	.050"x.039" (1.25x1.00mm)	.050"x.039" (1.25x1.00mm)	.063"x.055" (1.60x1.40mm)	.063"x.055" (1.60x1.40mm)	.050"x.039" (1.25x1.00mm)
	GAUGE	18GA	18GA	16GA	16GA	18GA
TOOL INFO	WEIGHT	5.08 lbs (2.31kgs)	2.90 lbs (1.32kgs)	3.78 lbs (1.72kgs)	2.88 lbs (1.31kgs)	2.27 lbs (1.03kgs)
	LOADING CAPACITY	110 nails	110 nails	105 nails	87 nails	135 nails
	OPERATION PRESSURE	70-120psi	70-120psi	70-120psi	70-120psi	70-120psi
	ACCESSORIES	2nd safety device quick jam release	quick jam release			

*Finish Nailer*



NAIL-DRIVING WITH SAFETY DEVICE:  
Slim nose easy aim  
(U.S. PATENT 6450387)

UNIQUE DRY-FIRE LOCK DESIGN  
(U.S. PATENT 7004368)

## BRADDER/ PIN NAILER System

**APPLICATION**  
DOOR AND WINDOW CASING / PANEL ASSEMBLY FURNITURE FRAMES TRIM / INTERIOR AND EXTERIOR TRIM BUTT JOINTS CABINETS



# BRADDERS/ PIN NAILERS



		PR-2145S	PR-2345S
NAIL SPEC	LENGTH	9/16"-1 3/4" (15-45mm)	9/16"-1 3/4" (15-45mm)
	SHANK	.033" (0.84mm)	.031" (0.80mm)
	HEAD DIA.	.055" (1.40mm)	.025" (0.64mm)
	GAUGE	21GA	23GA
TOOL INFO	WEIGHT	2.42 lbs (1.10kgs)	2.46 lbs (1.12kgs)
	LOADING CAPACITY	165 nails	200 nails
	OPERATION PRESSURE	70-120psi	70-120psi
	ACCESSORIES		

**Pin Nailer**

		PR-1565DA	PR-1550A	PR-1650A	PR-1850A
NAIL SPEC	LENGTH	1"-2 1/2" (25-65mm)	3/4"-2" (20-50mm)	3/4"-2" (20-50mm)	3/4"-2" (20-50mm)
	HEAD DIA.	.122" (3.10mm)	.122"-.133" (3.10-3.40mm)	.118" (3.00mm)	.075" (1.90mm)
	W X T	.075"x.063" (1.90x1.60mm)	.075"x.063" (1.90x1.60mm)	.063"x.055" (1.60x .40mm)	.050"x.039" (1.25x1.00mm)
	GAUGE	15GA	15GA	16GA	18GA
TOOL INFO	COLLATION ANGLE	34°	26°	26°	26°
	WEIGHT	3.59 lbs (1.63kgs)	2.93 lbs (1.33kgs)	2.95 lbs (1.34kgs)	2.95 lbs (1.34kgs)
	LOADING CAPACITY	148 angled brads	100 angled brads	100 angled brads	128 angled brads
	OPERATION PRESSURE	70-120psi	70-120psi	70-120psi	70-120psi

**Bradder**

# FLOORING FASTENING SYSTEM



EXTRA-WIDE COMPOSITE BASE PLATE FOR ADDED STABILITY.

Mallet and SERVICE PARTS BAG INCLUDED



▲ SPECIAL MAGAZINE DESIGN. FOR EASY LOADING AND OPERATION

		PR-9040FL	FS-50(R)	LFN-50B18(R)	LFN-50B(R)		PR-2032FL
NAIL SPEC	LENGTH	1/2"-1 5/8" (12-40mm)	1 1/4"-2" (32-50mm)	1 1/4"-2" (32-50mm)	<i>L shape cleat nail</i> 1 1/4"-2" (32-50mm)	<i>T shape cleat nail</i> 1 1/4"-2" (32-50mm)	1"-1 1/4" (25-32mm)
	HEAD DIA.			.287" (7.30mm)	.287" (7.30mm)	.236" (6.0mm)	.189" (4.80mm)
	CROWN SIZE	7/32" (5.80mm)	1/2" (13.00mm)				
	W X T	.050"x.039" (1.25x1.00mm)	.075"x.065" (1.90x1.64mm)	.118"x.047" (3.00x1.20mm)	.118"x.063" (3.00x1.60mm)	.063" (1.60mm)	.075"x.035" (1.90x0.90mm)
	GAUGE	18GA	15-15.5GA	18GA	16GA	16GA	20GA
TOOL INFO	WEIGHT	3.85 lbs (1.75kgs)	9.15 lbs (4.16kgs)	8.98 lbs (4.08kgs)	10.23 lbs (4.65kgs)	10.23 lbs (4.65kgs)	3.45 lbs (1.57kgs)
	LOADING CAPACITY	215 staples	130 staples	120 staples	120 staples	120 staples	240 staples
	OPERATION PRESSURE	70-120psi	70-120psi	70-120psi	70-120psi	70-120psi	70-120psi
	ACCESSORIES	roller	(R)for roller system		(R)for roller system		

## FLOORING FASTENING System

**APPLICATION**  
HARDWOOD FLOORING

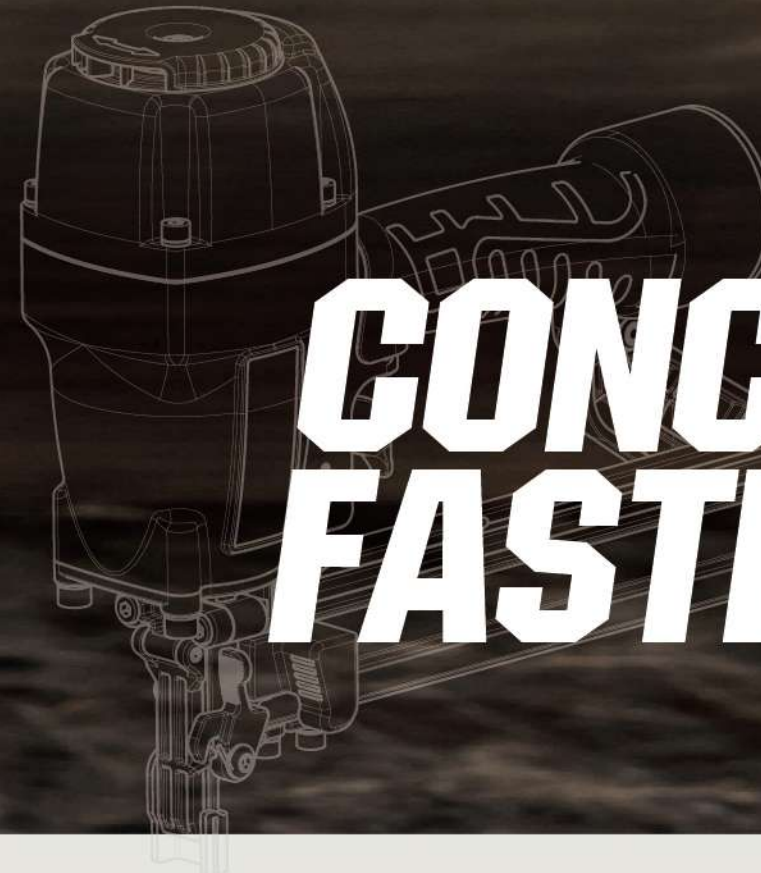

# CONCRETE FASTENING SYSTEM



		<b>PR-1.8 50C</b>	<b>PT-2575</b>	<b>PT-3040</b>	<b>PCN-50ST.2</b>	<b>PCN-650ST</b>	<b>PCN-670ST</b>
<b>NAIL SPEC</b>	<b>LENGTH</b>	9/16"-2" (15-50mm)	3/4"-3" (19-75mm)	9/16"-1 5/8" (15-40mm)	3/4"-2" (19-50mm)	1"-2" (25-50mm)	1"-2 3/4" (25-70mm)
	<b>SHANK</b>	.070" (1.80mm)	.086"-.099" (2.20-2.50mm)	.102"-.118" (2.60-3.00mm)	.083"-.113" (2.10-2.87mm)	.099"-.131" (2.50-3.30mm)	.099"-.131" (2.50-3.30mm)
	<b>HEAD DIA.</b>	.118" (3.00mm)	MAX .275" (7.00mm)	MAX .260" (6.60mm)	MAX .252" (6.40mm)	.236"-.283" (6.00-7.20mm)	MAX .283" (7.20mm)
	<b>GAUGE</b>	15GA	14GA		6.8-8.0mm	7.5-8.0mm	7.5-8.0mm
<b>TOOL INFO</b>	<b>WEIGHT</b>	3.26 lbs (1.48kgs)	6.67 lbs (3.03kgs)	6.67 lbs (3.03kgs)	5.48 lbs (2.49kgs)	6.69 lbs (3.04kgs)	6.73 lbs (3.06kgs)
	<b>LOADING CAPACITY</b>	77 nails	80 nails	36 nails	124-200 nails	150-300 nails	150-300 nails
	<b>OPERATION PRESSURE</b>	70-120psi	80-120psi	80-120psi	70-120psi	70-120psi	70-120psi
	<b>ACCESSORIES</b>						

# DRYWALL/SCREW FASTENING SYSTEM



**PCN-450DW**

**PRN-50**

**PRN-50DW**

**PCN-890H**

		PCN-450DW	PRN-50	PRN-50DW	PCN-890H
<b>NAIL SPEC</b>	LENGTH	1"-2" (25-50mm)	1"-2" (25-50mm)	1"-2" (25-50mm)	2"-3 1/2" (50-90mm)
	SHANK	.086"-.138" (2.20-3.50mm)	.118"-.161" (3.00-4.10mm)	.118"-.161" (3.00-4.10mm)	.118"-.161" (3.00-4.10mm)
	HEAD DIA.	MAX .323" (8.2mm)	MAX .315" (8.0mm)	MAX .338" (8.6mm)	MAX .338" (8.6mm)
	PITCH	7.5-8.0mm	8.0mm	10.0mm	7.5-10.0mm
<b>TOOL INFO</b>	WEIGHT	4.09 lbs (1.86kgs)	5.68 lbs (2.58kgs)	5.46 lbs (2.48kgs)	8.07 lbs (3.67kgs)
	LOADING CAPACITY	200 nails	150-250 nails	150-250 nails	150-250 nails
	OPERATION PRESSURE	70-120psi	70-120psi	70-120psi	70-120psi
	ACCESSORIES				

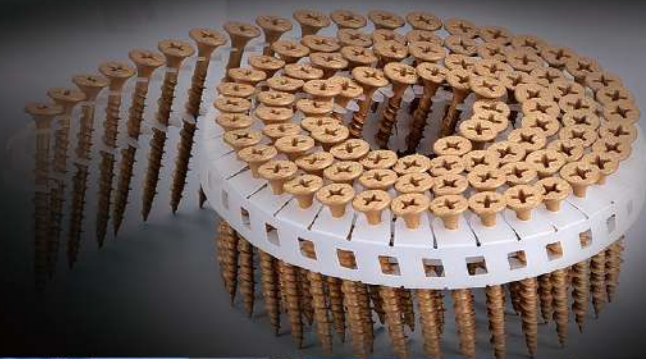

# C-RING TOOL / HOG-RING GUN



Long nose



		PSC-7E	PSC-7	PSC-7C	PSC-660
NAIL SPEC	LENGTH	.311"-.421" (7.90-10.70mm)	.311"-.421" (7.90-10.70mm)	.189"-.343" (4.80-8.70mm)	.099"-.138" (2.50-3.50mm)
	SHANK	.069"-.070" (1.75-1.80mm)	.069"-.070" (1.75-1.80mm)	.069"-.070" (1.75-1.80mm)	.063" (1.60mm)
	SHANK	15/16" x 15/32" (24.0 x 12.0mm)	15/16" x 15/32" (24.0 x 12.0mm)	15/16" x 15/32" (24.0 x 12.0mm)	21/32" x 11/32" (16.8 x 9.0mm)
	CROWN SIZE	15GA	15GA	15GA	16GA
TOOL INFO	WEIGHT	2.57 lbs (1.17kgs)	2.60 lbs (1.18kgs)	2.90 lbs (1.32kgs)	2.90 lbs (1.32kgs)
	LOADING CAPACITY	130 nails	130 nails	130 nails	130 nails
	OPERATION PRESSURE	70-120psi	70-120psi	70-120psi	70-120psi
	ACCESSORIES				

# SPECIAL FASTENING SYSTEM



	<b>FS-3140</b>	<b>PF-902 1D</b>	<b>PR-2380A</b>	<b>PR-8034M</b>
	Fence staple	Duplex Nails		Anchor Nails
<b>LENGTH</b>	1"-2" (25-50mm)	3"-3 1/2" (75-90mm)	2"-3 1/8" (50-80mm)	3 1/8" (80mm)
<b>CROWN SIZE</b>	1/2" (12.80mm)			
<b>W X T</b>	.131"-.110" (3.30-2.80mm)			
<b>GAUGE</b>	10.5GA			
<b>SHANK</b>		.113"-.131" (2.87-3.30mm)	.092" (2.30mm)	.252"-.264" (6.40-6.70mm)
<b>HEAD DIA.</b>		.315" (8.0mm)	.131"-.141" (3.33-3.57mm)	.472"-.488" (12.0-12.4mm)
<b>COLLATION ANGLE</b>		0°	34°	34°
<b>WEIGHT</b>	6.16 lbs (2.80kgs)	7.99 lbs (3.63kgs)	6.36 lbs (2.89kgs)	14.45 lbs (6.57kgs)
<b>LOADING CAPACITY</b>	75 staples	59 nails	100 nails	33 nails
<b>OPERATION PRESSURE</b>	80-120psi	80-120psi	70-120psi	80-120psi
<b>ACCESORRIES</b>				

# ACCESSORIES

## ▼ Hook

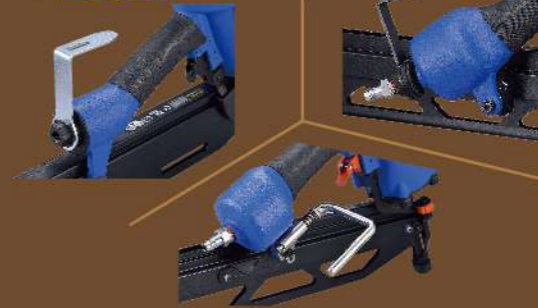

## ▼ EXTENDED MAGAZINE



## ▼ Piston Driver

INTERCHANGEABLE WITH MAX / HITACHI / BOSTITCH

BRAND NAME	MODEL	PARTS #
MAX	CN55	MA31866
MAX	CN70	MA31657
MAX	CN80	MA34445
PASLODE	F350S	PA501042
PASLODE	F250S-PP	PA501468
PASLODE	5250-PP	PA401933
PASLODE	3150W16	PA404345
BOSTITCH	RN45B	BO101961
BOSTITCH	RN46	BO149826
BOSTITCH	N70	BO102630
BOSTITCH	N80	BO80157
BOSTITCH	N100	BO100157
BOSTITCH	N400	BO11204-1030001
BOSTITCH	64084	11204-0780009
BOSTITCH	64099	11204-1010001

BRAND NAME	MODEL	PARTS #
HITACHI	NV45AB2	HI-878156
HITACHI	NR65AK	HI-883471
HITACHI	NR83A2	HI-877323
HITACHI	NR90AD	HI-884957
HITACHI	NR90AE	HI-885519
HITACHI	NV75AG	HI-883980
HITACHI	NR83AA2	HI-883510
HITACHI	NR83A	HI-877323-R
HITACHI	NV83A	HI-878428
HITACHI	N5008AC	HI-883716
HITACHI	NV65AH	HI-882684

